

# MERCURY SERIES

## MER-531-20GM/C-P



- Ultra small, light and robust
- 1" Global Shutter CMOS sensor
- Compatible with GenICam™ and GigE Vision®
- Gigabit Ethernet Interface
- Power over Ethernet (PoE)
- 5.3 Megapixels
- 2 Programmable GPIOs

The MERCURY GigE PoE series(MER-G-P) camera is DAHENG IMAGING's mature area scan industrial digital camera, featuring outstanding performance, compact design and extremely low noise.

The MER-531-20GM/C-P camera is a monochrome/color GigE Vision camera with the Onsemi PYTHON 5000 CMOS sensor. Thanks to the extremely compact (29mm × 29mm × 38.3mm), robust metal housings and locking screw connectors, the MERCURY cameras can secure the reliability of cameras deployed in harsh environments.

The MER-531-20GM/C-P camera is powered over Ethernet and has opto-isolated I/Os. The GPIOs give MER-G-P maximum flexibility to adapt to specific needs. The camera has an outstanding price/performance ratio.

The MERCURY family cameras are especially suitable for machine vision applications such as industrial inspection, medical, scientific research, education, security and so on.

### Features

- Power over Ethernet (IEEE802.3af compliant)
- 10-bit or 8-bit Mono/Bayer output
- Programmable ROI, increased frame rate with partial scan
- Gain, exposure and white balance programmable (white balance only for color models)
- Support auto gain, auto exposure and auto white balance (auto white balance only for color models)
- Three acquisition controls: Continuous acquisition/Software trigger acquisition/External trigger acquisition
- Support ExposureEnd Event notification
- Color models support defect pixel correction
- Support Reverse X/Y
- Flash sync for firing external lights at precisely the moment when exposure is performed
- Adjustable packet-size and packet-delay, and reserved bandwidth
- Programmable LUTs and storable user sets
- Robust full metal housing and optional lockable devices
- Compatible with GenICam™ and GigE Vision®, support a variety of 3rd-party software such as HALCON, MERLIC and LabVIEW
- Optimized software package for 32/64bit Windows, and support Linux, ARMv7 and ARMv8
- Multiple samples and easy-to-integrate SDKs for various programming tools
- Regulations: CE, RoHS, FCC, GenICam, GigE Vision, IEEE802.3af (PoE)

### Performance Specifications

Model	MER-531-20GM/C-P
Interface	GigE
Resolution	2592(H) × 2048(V)
Frame rate	20 fps
Sensor	1" ,Global Shutter Onsemi PYTHON 5000 CMOS
Pixel size	4.8 μm × 4.8 μm
Pixel Bit Depth	8bit, 10bit
Spectrum	Monochrome / Color
Exposure time	5μs~1s

### Optical Specifications

Lens mount	C-Mount (standard), CS-Mount (optional)
------------	---

### Electrical Specifications

Power requirement	12 VDC via 8-Pin or PoE
I/Os	1 input / 1 output, 2 GPIOs
Data interface	RJ45
Power consumption	<3W @ 12V, <3.75W @ PoE

### Environmental Specifications

Operating temp.	0°C ~ +45°C
Storage temp.	-20°C ~ +70°C
Operating humidity	10% ~ 80%

### Mechanical Specifications

Weight	75g
Dimensions	29(W)×29(H)×38.3(L)mm, w/o connectors

### Technical Drawing

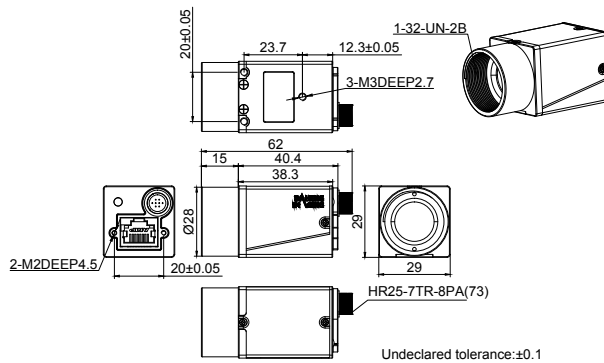

Units: mm

### Spectral Response

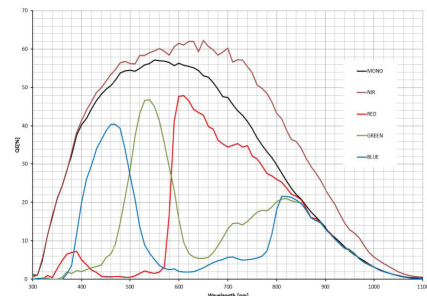

MER-531-20GM/C-P

China Daheng Group, Inc. Beijing Image Vision Technology Branch

12F Daheng Science & Technology Tower, No.3 Suzhou Street, Haidian District,

Beijing China, 100080

Tel: +86 10 82828878

E-mail: isales@daheng-imaging.com

For more information please visit : [www.daheng-imaging.com/en](http://www.daheng-imaging.com/en)

Specifications are subject to change without prior notice.

Copyright © 2021 China Daheng Group, Inc. Beijing Image Vision Technology Branch. All rights reserved.

November 17, 2021