

# MERCURY2 FAMILY

## MER2-507-23GM NIR



- Optimized NIR response
- 5.0 Megapixels
- 1/2.5" rolling shutter CMOS sensor
- Ultra small, light and robust
- Compatible with GenICam™ and GigE Vision®
- Gigabit Ethernet interface
- 2 programmable GPIOs

The MERCURY2 GigE series (MER2-G) camera is DAHENG IMAGING's new generation industrial digital camera. With improved built-in ISP algorithms, MER2-G series camera supports more features. Providing multiple acquisition controls, the camera can adapt to various vision applications.

The MER-507-23GM NIR camera is a NIR enhanced GigE Vision camera with the Onsemi AR0522 CMOS sensor, the sensor has optimized response in the near-infrared band. Thanks to the extremely compact (29mm × 29mm × 29mm), robust metal housings and locking screw connectors, the MERCURY2 cameras can secure the reliability of cameras deployed in harsh environments. The MER2-507-23GM NIR camera has opto-isolated I/Os. The GPIOs give MER2-G cameras maximum flexibility to adapt to specific needs.

The MERCURY2 family cameras are especially suitable for machine vision applications such as industrial inspection, medical, scientific research, education, security and so on.

### Features

- GigE interface with 12-bit or 8-bit Mono output
- Programmable ROI, increased frame rate with partial scan
- Gain and exposure programmable
- Support auto gain and auto exposure
- Support Black Level and Reverse X/Y (horizontal and vertical mirroring)
- Support Binning, Decimation, Digital Shift, Noise Reduction and Dynamic Defect Pixel Correction
- Adjustable Gamma and Sharpness for optimizing the brightness and sharpness of images
- Programmable LUTs and storable user sets
- Support Timer and Counter
- Adjustable packet-size and packet-delay, and reserved bandwidth
- Support Remove Parameter Limit to expand the range of exposure, gain, and so on
- 16KB data storage area for saving algorithm coefficients and parameter configuration
- Compatible with GenICam™ and GigE Vision®, can be used in a wide range of 3rd-party software such as HALCON, MERLIC and LabVIEW directly
- Optimized software package for 32/64bit Windows, and support Linux, ARMv7、ARMv8 and Mac OS
- Multiple samples and easy-to-integrate SDKs for various programming tools
- Regulations: CE, FCC, RoHS, GenICam, GigE Vision

### Performance Specifications

Model	MER2-507-23GM NIR
Interface	GigE
Resolution	2592(H) × 1944(V)
Frame rate	23.3 fps @2592 × 1944
Sensor	1/2.5" Onsemi AR0522 Rolling shutter CMOS
Pixel size	2.2 μm × 2.2 μm
Pixel Bit Depth	8bit, 12bit
Spectrum	Monochrome / NIR
Exposure time	20μs~1s

### Electrical Specifications

Power requirement	12~24 VDC via 8-Pin connector
I/Os	1 input / 1 output, 2 GPIOs
Data interface	RJ45
Power consumption	<3W@24VDC

### Environmental Specifications

Operating temp.	0°C ~ +45°C
Storage temp.	-20°C ~ +70°C
Operating humidity	10% ~ 80%

### Optical Specifications

Lens mount	C-Mount (standard), CS-Mount (optional)
------------	---

### Mechanical Specifications

Weight	65g
Dimensions	29(W)x29(H)x29(L)mm, w/o connectors

### Technical Drawing

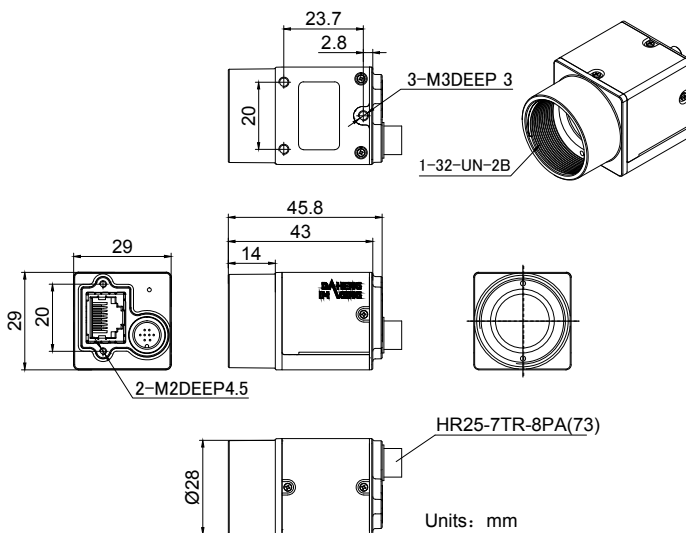

### Spectral Response

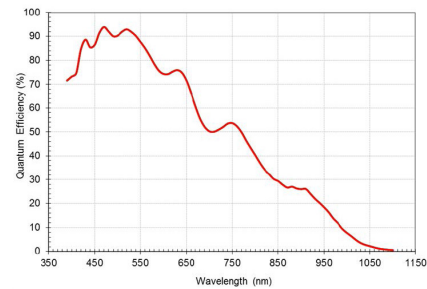

MER2-507-23GM NIR

China Daheng Group, Inc. Beijing Image Vision Technology Branch

12F Daheng Science & Technology Tower, No.3 Suzhou Street, Haidian District,

Beijing China, 100080

Tel: +86 10 82828878

E-mail: isales@daheng-imaging.com

For more information please visit: [www.daheng-imaging.com/en](http://www.daheng-imaging.com/en)

Specifications are subject to change without prior notice.

Copyright © 2022 China Daheng Group, Inc. Beijing Image Vision Technology Branch. All rights reserved.

11093016